

BLADE ASSEMBLY AND

NOTE: The blades should be attached to the fan after it is hung and wired to prevent blade brackets from being bent and causing the fan to wobble.

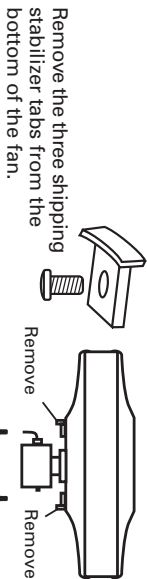

1. Using three phillips washer head screws, secure one bracket to each of the blades. Complete this assembly before attaching blades to ceiling fan. (Figure 6)

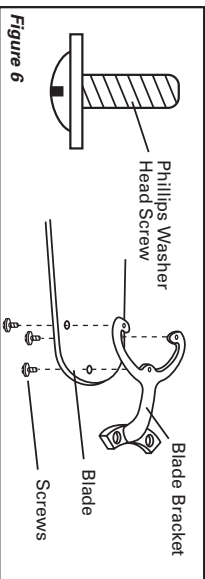

2. Place one of the phillips pan head screws into one of the recessed holes in the blade bracket. Turn screw until it mates with threaded hole in hub. Do not tighten screw completely at this time. (Figure 7)
3. Install the second screw in the same manner, then tighten both screws firmly.
4. Install the remaining blade assemblies by repeating the above steps.

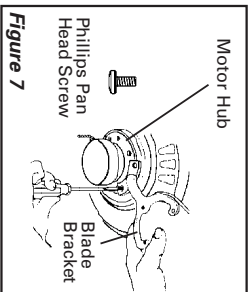

LIGHT KIT INSTALLATION

1. Connect the black wire in the light fitter with the blue wire marked "For Light" using the supplied wire nuts. (Figure 8)
2. Connect the white wire in the light fitter with the white wire marked "For Light" using the supplied wire nuts.
3. Tuck the wires and wire nuts into switch cup. Lift the light fitter into place and insert the three screws and tighten.
4. Install light bulb (not included) and lift globe into place and secure with the three thumb screws. Do not overtighten.

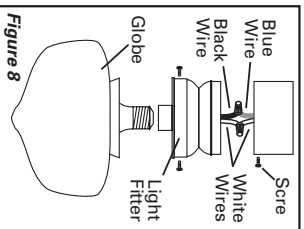

USING YOUR CEILING FAN

1. Restore power to the electrical box.
2. Check the operation of the fan by gently pulling the chain switch.
3. To reverse airflow direction, turn fan off and wait for the blades to come to a full stop, then slide reversing switch to opposite position. (Figure 9)
4. Your ceiling fan is equipped with four position, three speed pull chain switch.

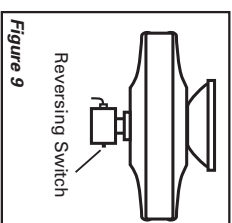

MAINTENANCE

Periodic cleaning of your ceiling fan is the only maintenance that is needed. When cleaning, use only a soft brush or lint free cloth to avoid scratching the finish. Abrasive cleaning agents are not required and should be avoided to prevent damage to the finish. Do not spray water directly onto your ceiling fan. It could damage the motor or the blades and create the possibility of an electrical shock or fire.

WARRANTY

The ceiling fan you have purchased is warranted by the manufacturer for one year from the date of purchase against defects in workmanship and/or materials. The motor is warranted for ten years. This warranty means that only the parts that prove to be defective during the period of warranty will be either repaired or replaced at our option. The right is reserved by the manufacturer to replace the whole product in lieu thereof. Should repair become necessary during the warranty period, write to: **AIR KING c/o LASKO PRODUCTS, INC., Appliance Service Department, 820 Lincoln Ave., West Chester, PA 19380.** Describe the problem you are having. **DO NOT SEND FANI!**

This warranty does not apply if the damage occurs because of accident, improper handling, installation or operation, shipping damage, abuse, misuse or unauthorized repairs made or attempted. **ALL WARRANTIES, EXPRESSED OR IMPLIED LAST FOR ONE YEAR FROM DATE OF ORIGINAL PURCHASE, EXCEPT FOR THE MOTOR. THIS WARRANTY DOES NOT COVER LIABILITY FOR INCIDENTAL OR CONSEQUENTIAL DAMAGES FOR ANY CAUSE WHATSOEVER.** Some states do not allow limitations on how long any implied warranty lasts, or the exclusion or limitations of incidental or consequential damages, so that the above limitation or exclusion may not apply to you. This warranty gives you specific legal rights, and you may have other rights that vary from state to state. **FOR REPLACEMENT PARTS:** Please call 1-800-966-2028, Monday - Friday, between the hours of 8am and 4 pm EST. Reference the type and style of product when you call.

FOR QUESTIONS OR COMMENTS ABOUT YOUR CEILING FAN: Please call 1-800-233-0268, Monday - Friday, between the hours of 8am and 4pm EST.

New 11/00

INSTRUCTION MANUAL

Air King
Ventilation Products®

Model 9898L

BUILDER'S CHOICE

52" PORCH CEILING FAN



READ AND SAVE THESE

Your new ceiling fan is UL listed and will require a grounded electrical supply line of 120 volts AC, 60 Hz, 15 amp circuit. The 52" total fan weight is 26 lbs maximum.

WARNING: To reduce the risk of fire, electrical shock or personal injury, mount fan at least 7 feet above the floor to an outlet box marked "Acceptable for fan support." Use screws provided with outlet box. Most outlet boxes commonly used for the support of lighting fixtures are not acceptable for fan support and may need to be replaced. Consult a qualified electrician if in doubt.

Your ceiling fan will fit any of the following electrical boxes: 4" octagon box, 3" octagon box, 1/2" deep ceiling pan, or a plaster ring with 3 1/2" mounting hole centers mounted on one of the above listed boxes. Your new fan will also install on a "wire mold" No. 5738 fixture box. The electrical box must be securely anchored an capable of withstanding a load of at least 50 pounds.

If your ceiling fan does not have one of the above electrical boxes for proper wiring, you may wish to contact a licensed electrician for installation.

RULES FOR SAFE INSTALLATION

- Follow the recommended instructions for the proper method of wiring your ceiling fan. If you do not know enough about electrical wiring, have your fan installed by a licensed electrician.
- All wiring must satisfy National and Local electrical codes. The ceiling fan must be grounded as a precaution against possible electrical shock.
- The electrical outlet box and joist must be securely mounted and capable of reliably supporting at least 50 pounds.
- WARNING: To reduce the risk of fire, electrical shock and/or personal injury:**
 - Be sure electricity is turned off at the main fuse box before wiring, cleaning or servicing.
 - Fan should not be mounted in areas where it might come in direct contact with water.

RULES FOR SAFE OPERATION

- Be careful of the fan and moving blades when cleaning, painting or working near fan.
- Do not put anything into the blades while they are turning.
- Do not bend the blade brackets when installing the brackets, balancing the blades or cleaning the fan.
- WARNING: The fan must be hung with at least 7 feet of clearance from floor to blades.**

INSTALLATION INSTRUCTIONS

- Attach the hanger bracket to the electrical box capable of reliably supporting at least 50 pounds. Insert the screws through the slotted holes in the bracket and attach to the electrical box. Tighten both screws to the electrical box. (Figure 1)

NOTE: If bracket and/or electrical box are not securely attached, the fan could wobble.

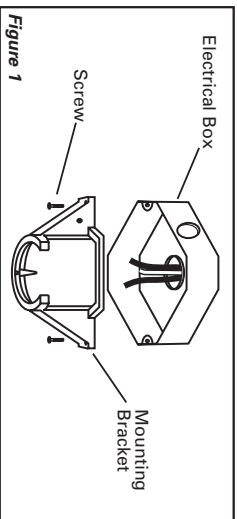

Figure 1

- Install motor leads through the canopy then through the hole in the center of the pipe flange. Insert downrod into downrod yoke. Make sure to align hole in downrod with hole in downrod yoke. Lift canopy and install yoke cross pin through yoke and downrod. Insert cotter pin into cross pin until it snaps into place. Using a phillips head screwdriver firmly tighten set screws in yoke. (Figure 2)

WARNING: Failure to completely install the cotter pin or tighten the set screw could result in the fan loosening and possibly falling.

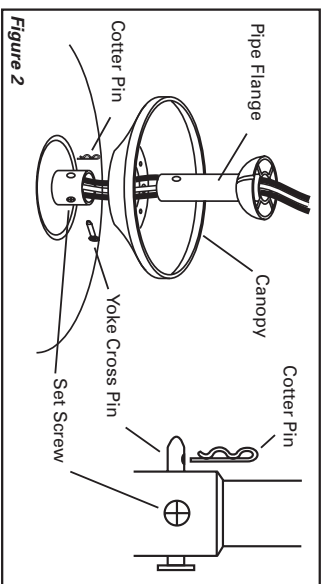

Figure 2

- Carefully lift the fan and seat the pipe flange and ball assembly on the hanger bracket that was just attached to the electrical box. Be sure the notch on the side of the ball is lined up with tab on the hanger bracket. (Figure 3)

WARNING: Failure to seat tab on bracket into notch on ball could cause damage to electrical wires and cause fan to fall.
NOTE: Do not pinch wires between the ball and pipe flange assembly and hanger bracket.

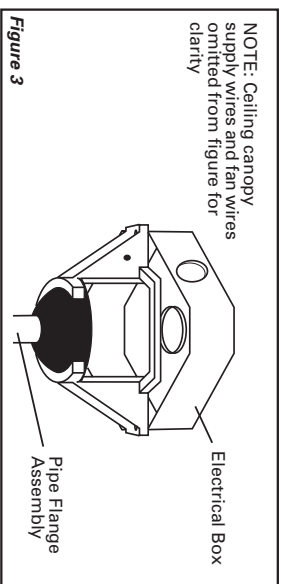

Figure 3

NOTE: Ceiling canopy supply wires and fan wires omitted from figure for clarity

- Make sure the electrical box is properly secured. If romex cable (plastic sheathed) was used to wire the electrical box, the presence of a third wire connected to the electrical box indicates that the box is grounded. This ground wire may be bare wire (no insulating jacket), or a green insulated wire. The two supply wires will be white and black insulated wires.
- If the wiring to the electrical box is enclosed in electrical conduit pipe, the ground wire may not be present. The conduit itself could serve as the ground.

GROUNDING:

- Romex (plastic sheathed) Cable:** If romex cable was used to wire the electric box, connect the green ground wire in the Romex cable using a 7/2B listed wire nut.
- Conduit Pipe:** If the wiring to the electrical box is enclosed in electrical conduit pipe, connect the ground wire to the ground screw in the electrical box.

- Electrical Supply:** Connect the fan motor white wire to the supply white (Neutral) wire using a listed wire nut. Connect the fan motor black wire and blue wire to the supply black (hot) wire using a listed wire nut. Your fan is now wired to be turned on and off from the fan (pull chain) switch. (Figure 2) With wire nuts turned upward, place green and white connections to one side of box and blue and black connections towards the other side and push carefully up into outlet box.

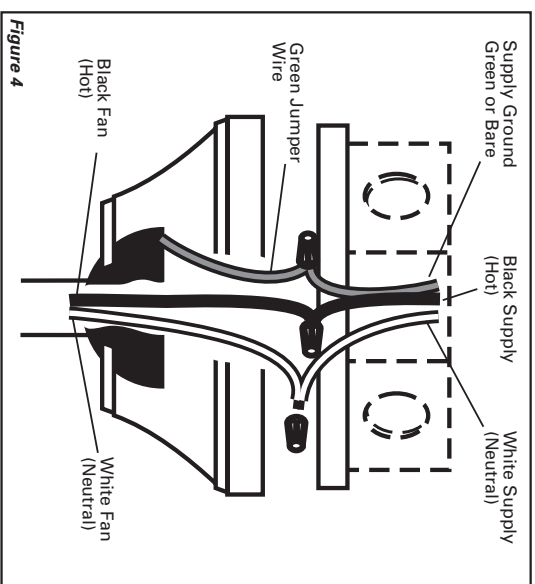

Figure 4

NOTE: Check to see that all connections are tight, including the ground and that no bare wire is visible at the wire nuts, except for the ground wire.

- Raise canopy up to mounting bracket and fit screws into slots on canopy and rotate to the left to lock into place. Tighten both screws. (Figure 5)

NOTE: Make sure that the electrical wires are completely inside the electrical box and not pinched between the ceiling canopy and the ceiling.

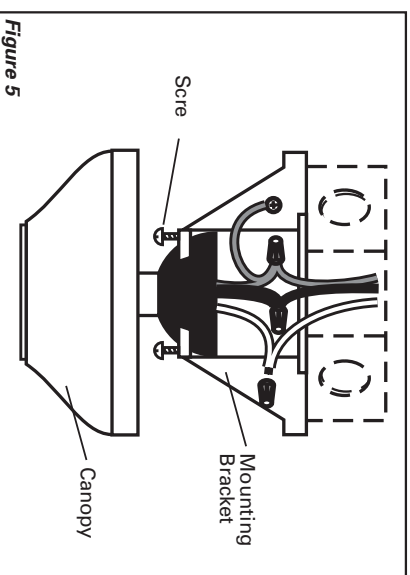

Figure 5